

# SB SOUNDBARS

# SB MULTI-USE SPEAKERS

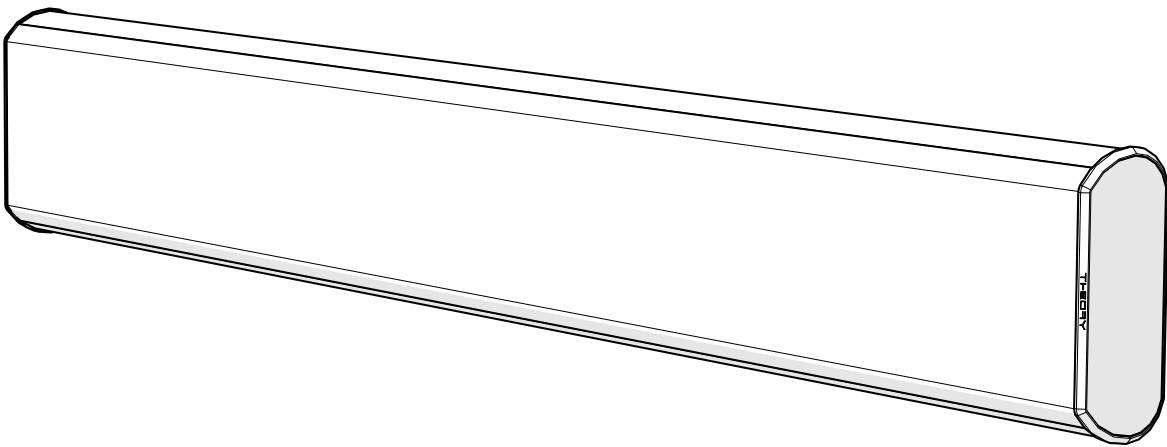

QUICK START INSTALLATION  
GUIDE

Rev A 191104

THEORY  
THEORY AUDIO DESIGN

## LIMITED WARRANTY

Disclaimer : THEORY AUDIO DESIGN, LLC is not liable for any damage to loudspeakers or any other equipment that is caused by negligence or improper use or installation of this product, including damage caused by connecting Theory loudspeakers and subwoofers to third party amplifiers.

### **THEORY AUDIO DESIGN, LLC 5-Year Limited Loudspeaker and Subwoofer Warranty**

THEORY AUDIO DESIGN, LLC guarantees its loudspeaker and subwoofers products to be free from defective materials and/or workmanship for a period of five (5) years from the date of sale, and will replace defective parts and/or repair malfunctioning products under this warranty when the defect occurs under normal installation and use - provided that the unit is returned to our factory or one of our authorized service centers via prepaid transportation with a copy of proof of purchase (sales receipt). This warranty provides that the examination of the return must indicate, in our judgment, a manufacturing defect. This warranty does not extend to any product which has been subject to misuse, neglect, accident, improper installation or where the date code has been removed or defaced. THEORY shall not be liable for incidental and/or consequential damages. The warranty gives you specific legal rights. This limited warranty is not transferable. Customer may have rights which vary from state to state.

In the event that this product was manufactured for export and sale outside of the United States or its territories, then this limited warranty does not apply. Removal of the serial number on this product, or purchase of this product from an unauthorized dealer will void this limited warranty.

### **EXCLUSIONS**

To the extent permitted by law, the warranty set forth above is in lieu of, and exclusive of, all other warranties, express or implied, and is the sole and exclusive warranty provided by Theory Audio Design, LLC. All other express and implied warranties, including the implied warranties of merchantability, implied warranty of fitness for use, and implied warranty of fitness for a particular purpose are specifically excluded.

Theory Audio Design, LLC shall not be liable for consequential, incidental, economic, property, bodily injury, or personal injury damages arising from the product, any breach of this warranty or otherwise.

This warranty statement gives you specific legal rights, and you may have other rights which vary from state to state. Some states do not allow the exclusion of implied warranties or limitations of remedies, so the above exclusions and limitations may not apply. If your state does not allow disclaimer of implied warranties, the duration of such implied warranties is limited to period of THEORY'S express warranty

Periodically this warranty is updated. To obtain the most recent version of THEORY'S warranty statement, please call +1-949-245-0505.

## IMPORTANT SAFETY INSTRUCTIONS

1. Read all instructions.
2. Keep these instructions.
3. Heed all warnings.
4. Follow all instructions.
5. Do not use this apparatus near water.
6. To prevent fire or shock, do not expose this equipment to moisture or water.
7. Clean only with a dry cloth.
8. Install in accordance with manufacturer's instructions.
9. Do not install near any heat sources such as radiators, heat registers, stoves or other apparatus that produce heat.
10. Use only attachments/accessories specified by THEORY AUDIO DESIGN, LLC.
11. Use only with hardware, brackets, stands, and components sold with the apparatus or supplied by THEORY AUDIO DESIGN, LLC.
12. Do not install SPEAKERS or SOUNDBARS overhead.
13. Mount only to solid architectural walls.
14. Do not attempt to mount SPEAKERS or SOUNDBARS to your TV or TV mount.
15. Refer all servicing to qualified service personnel. Servicing is required when the apparatus is damaged in any way.
16. Mount Z-CLIP hardware to studs whenever possible. Use drywall anchors only when studs are not available.
17. Connect to Theory or Pro Audio Technology Amplified Loudspeaker Controllers ONLY. Do not connect to third-party amplifiers. Doing so will void the product warranty and potentially damage the loudspeaker.

## PARTS LEGEND

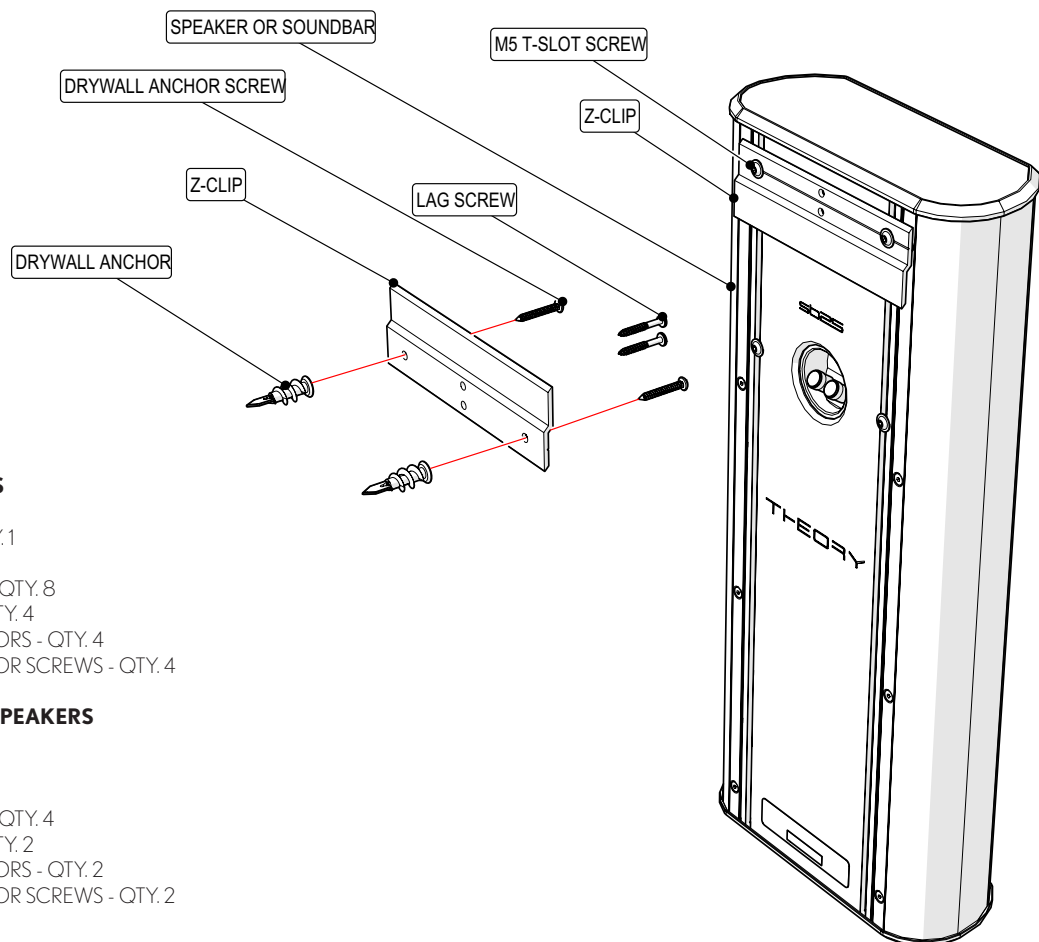

### PARTS LIST - SOUNDBARS

1. SOUNDBAR - QTY. 1
2. Z-CLIPS - QTY. 4
3. T-SLOT SCREWS - QTY. 8
4. LAG SCREWS - QTY. 4
5. DRYWALL ANCHORS - QTY. 4
6. DRYWALL ANCHOR SCREWS - QTY. 4

### PARTS LIST - MULTI-USE SPEAKERS

1. SPEAKER - QTY. 1
2. Z-CLIPS - QTY. 2
3. T-SLOT SCREWS - QTY. 4
4. LAG SCREWS - QTY. 2
5. DRYWALL ANCHORS - QTY. 2
6. DRYWALL ANCHOR SCREWS - QTY. 2

**SOUNDBAR MODELS**

**MOUNT TO WALL ONLY - GET HELP**

Your Theory SOUNDBAR is heavy and must be mounted securely to a wall, it cannot be mounted to your TV or TV mount.

You will need at least three people to safely mount your SOUNDBAR.

DO NOT TRY TO MOUNT YOUR THEORY SOUNDBAR BY YOURSELF.

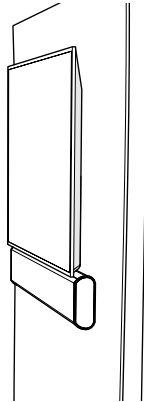

**1 - DETERMINE DESIRED POSITION**

Use the illustrations in FIGURE 1 as a guide for how you want to position the SOUNDBAR relative to your TV.

It can be positioned to appear to be mounted to the TV (FIGURE 1A), or it can be mounted to stand alone beneath the TV lower edge (FIGURE 1B).

If choosing tight spacing, make sure the TV does not touch the SOUNDBAR as the vibrations will cause an audible rattle. Leave a small gap between the TV and the SOUNDBAR itself.

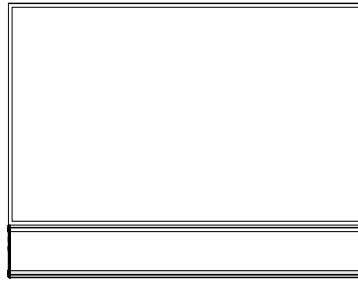

FIGURE 1A. The SOUNDBAR can be positioned closely to the TV for an integrated appearance.

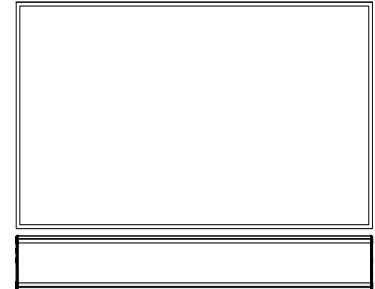

FIGURE 1B. The SOUNDBAR can be positioned with a gap below the TV for an independent appearance.

**2 - MARK LOCATION**

Using FIGURES 1A and 1B as guide, locate the desired position of the top center of your SOUNDBAR and make a small mark on the wall at this location.

Once you've located the top center, and using a bubble or laser level, draw a level line 2.7" below your top-center mark.

Measure the length of your soundbar and mark the end points of the SOUNDBAR on the line on either side of the center mark.

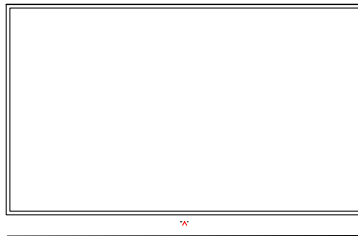

FIGURE 2. Place a mark at the desired top center location. Draw a level line 2.7" below the center mark the width of your SOUNDBAR.

**3 - LOCATE STUDS**

Next, using an electronic stud finder, locate and mark the stud locations on your line in between the center and end marks on both sides. Figure 3.

(Drywall is omitted for clarity).

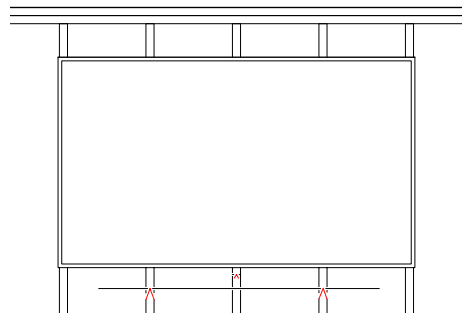

FIGURE 3. Identify the stud locations and mark them on your level line.

# QUICK START GUIDE - SB MODELS

## 4 - MOUNT WALL Z-CLIPS

Using the supplied lag screws and a laser or bubble level, mount the two supplied Z-CLIPS to one stud on each side of the center mark, positioning the top edge of the Z-CLIP on the line according to Figure 4A.

Select studs which are spaced within the ends of the SOUNDBAR length that are approximately 2/3 or greater the length of the SOUNDBAR apart. The stud locations may not be exactly centered on the SOUNDBAR.

Use 2 screws per Z-CLIP: install one first, level the Z-CLIP and then install the second screw. (Figure 4B). (If studs are not available, see ALTERNATE STEP4 on PAGE 4)

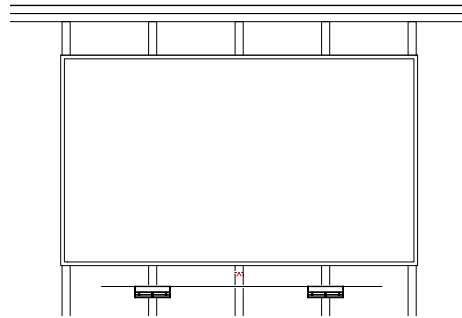

FIGURE 4A. Align Z-CLIP center mount holes with center of studs. (Drywall omitted for clarity).

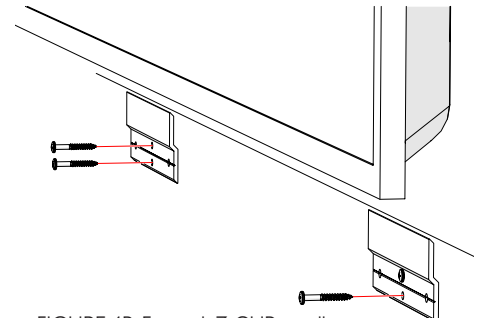

FIGURE 4B. For each Z-CLIP, install one screw first, level the Z-CLIP, then install the second screw.

## 5 - POSITION SOUNDBAR Z-CLIPS

Measure and record the distance from the center mark to the center of each Z-CLIP. (Figure 5A).

Using a 3mm hex key, loosen the M5 flanged cap screws on the SOUNDBAR Z-CLIPS and move them into the positions that correspond with the spacing of the wall Z-CLIPS. Keep in mind that the spacing will be reversed when viewing the SOUNDBAR Z-CLIPS from the rear. (Figure 5B).

Once in place, tighten the M5 bolts to lock the Z-CLIPS in position.

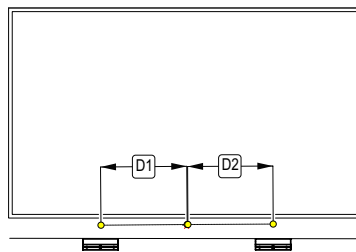

FIGURE 5A. Measure and record the distance from the center mark to each Z-CLIP

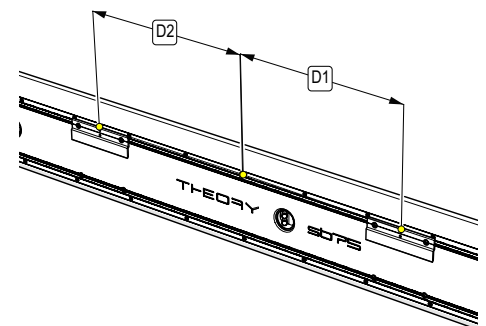

FIGURE 5B. Duplicate Z-CLIP spacing on rear of your Theory SOUNDBAR keeping in mind the spacing will be reversed.

## 6 - ROUTE SPEAKER WIRE

If you haven't already done so, run 3 speaker wires for LEFT, CENTER and RIGHT speakers to the SOUNDBAR center location.

Since the Z-CLIPS will position the SOUNDBAR back surface only 1/4" off the wall surface, flat ("zip cord") style speaker wire will be required and will easiest to conceal behind the SOUNDBAR.

Make sure to label the speaker wires at both ends for LEFT, CENTER and RIGHT.

## 7 - CONNECT WIRES

Connecting the wires and hanging the soundbar will require a MINIMUM OF THREE PEOPLE: one person lifting the SOUNDBAR at each end, and one person to connect the speaker wires to the spring terminals on the back side of the SOUNDBAR while the SOUNDBAR is held in position near the installation location.

The speaker wires may be placed in the SOUNDBAR T-SLOTS to hold them in place for convenience.

Connect the wires to the spring terminals observing the correct polarity. Note that the orientation of the spring terminals are opposite for LEFT and RIGHT connections.

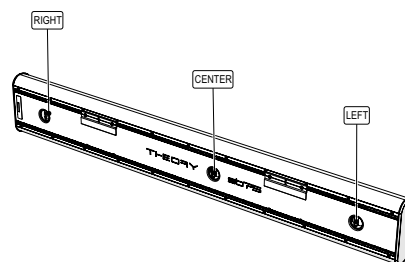

FIGURE 6A. Connect LEFT, CENTER and RIGHT speaker wires to terminals shown.

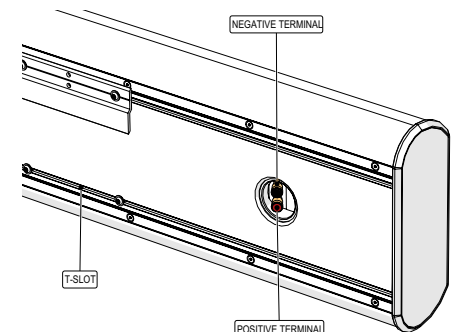

FIGURE 6B. Observe correct polarity: RED - POSITIVE; BLACK - NEGATIVE.

**8-MOUNT SOUNDBAR**

Once wires are connected and checked for polarity, position the SOUNDBAR such that the SOUNDBAR Z-CLIPS are tight against the wall surface and directly above the wall Z-CLIPS. (FIGURE 8A)

NOTE: IF MOUNTING THE SOUNDBAR TIGHT TO THE TV, YOU MAY NEED TO REMOVE THE TV FROM THE WALL TO MOUNT THE SOUNDBAR.

Slowly lower the SOUNDBAR until the speaker Z-CLIPS engage completely into the wall Z-CLIPS. Push down on the SOUNDBAR to insure the Z-CLIPS are fully engaged. (FIGURE 8B)

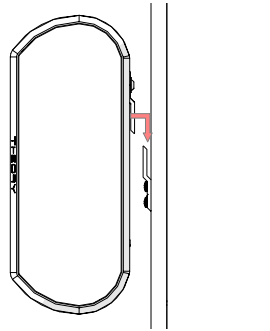

FIGURE 8A. Position the soundbar against the wall and above the wall Z-Clips.

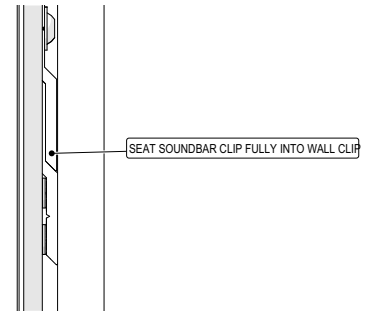

FIGURE 8B. Push down until both Soundbar Z-Clips seat fully into both wall Z-clips.

**ALTERNATE STEP 4 - STUD UNAVAILABLE**

When a stud is not available onto which to mount the wall Z-CLIPS, use the supplied drywall anchors as shown.

Mark the Z-CLIP outer hole positions on the wall and install the drywall anchors. (FIGURE ALT4A).

Align the Z-CLIP outer holes with the drywall anchors and fasten to the wall using the supplied drywall anchor screws. (FIGURE ALT4B).

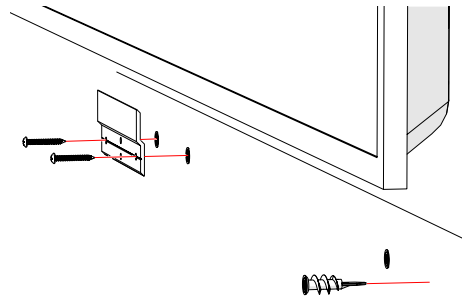

FIGURE ALT4A. Screw drywall anchors into drywall at Z-CLIP outer hole locations.

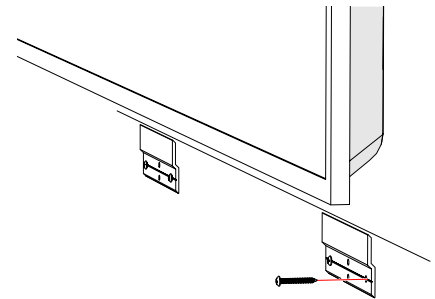

FIGURE ALT4B. Using supplied screws, fasten Z-CLIP to drywall anchors using supplied screws.

**MULTI-USE MODELS**

**SB MULTI-USE SPEAKERS**

Your SB MULTI-USE SPEAKER uses a single Z-CLIP pair to mount to a wall surface.

The SPEAKER Z-CLIP comes mounted to the speaker in portrait orientation (FIGURE 9A). For landscape mounting, the Z-CLIP may be attached to the SPEAKER along the same T-SLOT (FIGURE 9B).

Follow STEP 4 (or ALTERNATE STEP 4 if a stud is not available) to mount the wall Z-CLIP to the wall surface at the desired speaker location.

Follow STEP 8 to mount the SPEAKER to the wall. (FIGURE 9B)

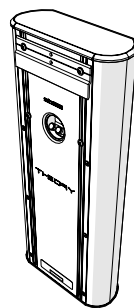

FIGURE 9A. SPEAKER Z-CLIP installed in portrait position. (Factory default).

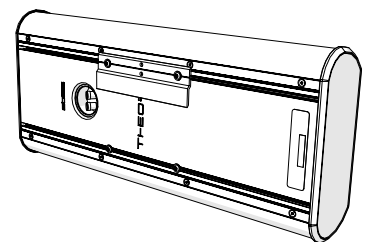

FIGURE 9B. Using a 3mm hex key, relocate SPEAKER Z-CLIP to a common T-SLOT, centered, for landscape orientation.

© 2019 THEORY AUDIO DESIGN, LLC. All rights reserved.

Theory Audio Design routinely engages in programs to improve, modify and revise its products without notice or obligation. As such, your product may differ slightly from what is shown in this guide.

**THEORY AUDIO DESIGN, LLC**  
25741 Atlantic Ocean Drive, Suite B  
Lake Forest, CA 92630

Tel: 949-245-0505  
www.theoryaudiodesign.com